

Panasonic®

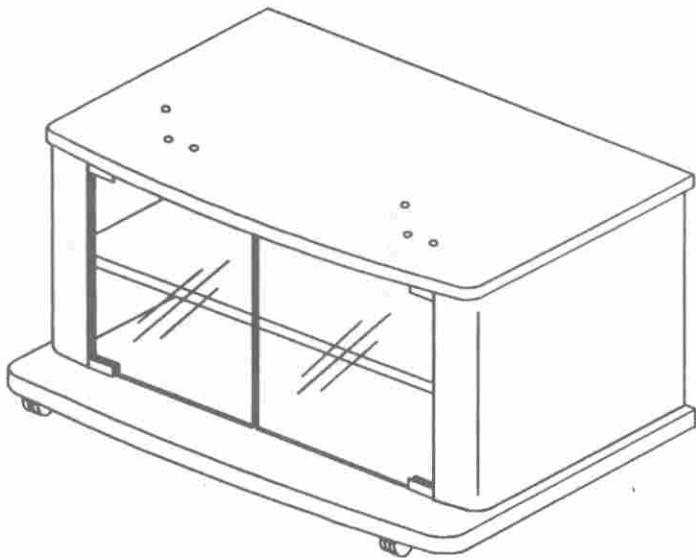

Assembly Instructions **TY-27G22M** VIDEO STAND

TOLL FREE CUSTOMER ASSISTANCE LINE
1-800-900-MICA (6422)

Monday – Thursday: 7:30 am – 4:30 pm E.S.T.
Friday: 7:30 am – 2:30 pm E.S.T.

Important

A study of the assembly instructions will not only save you time but may prevent possible damage to your new stand. Assistance may be required for some assembly procedures.

THIS STAND IS DESIGNED FOR USE WITH TELEVISIONS.
UL APPROVED MODELS: CT-27G2V, CT-27G2UV,
CT-27G12V, CT-27G12UV, CT-27G22V, CT-27G22UV,
CT-27G32V, CT-27G32UV, CT-2758SV, CT-2768SV,
CT-27S21V, SP2719V, SP2719UV, SP2729V,
SP2729UV, CT-27SF12T, CT-27SF14V,
CT-27SF24V, CT-27SF34V

The Tools Required:



Hammer













Philips
Screwdriver

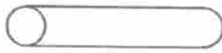
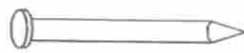

Slot
Screwdriver

Your Hardware Pack Contains / Replacement Parts

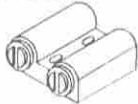
<p>Cam Lock Screw</p>  <p>8 Pcs. TKC2Q25131</p>	<p>Cam Lock Housing</p>  <p>8 Pcs. TKX2Q1162</p>	<p>Hinges</p>  <p>2 Bags TKC2Q25114</p>	<p>Dowels</p>  <p>12 Pcs. TKD2Q26023</p>
<p>Set Location Pin</p>  <p>2 Pcs. TKC2Q25094</p>	<p>Nail</p>  <p>9 Pcs. TKC2Q25112</p>	<p>Shelf Pin</p>  <p>4 Pcs. TKC2Q25036</p>	<p>Screw #6 x 5/8"</p>  <p>2 Pcs. THT2Q07B99B</p>
<p>Screw #8 x 5/8"</p>  <p>16 Pcs. THT2Q0FB76B</p>	<p>Caster</p>  <p>4 Pcs. 1 Bag TBL2QA4105</p>	<p>Touch Plate</p>  <p>2 Bags TKC2Q25082</p>	<p>Magnetic Latch</p>  <p>1 Pc. TKC2Q25015</p>

STEP 1

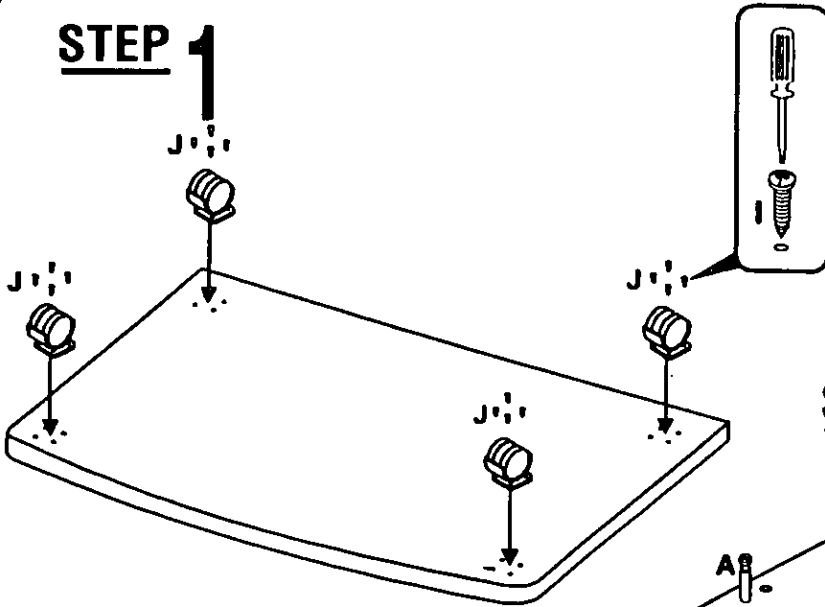

STEP 2

• Screw cam lock screws into bottom as illustrated.

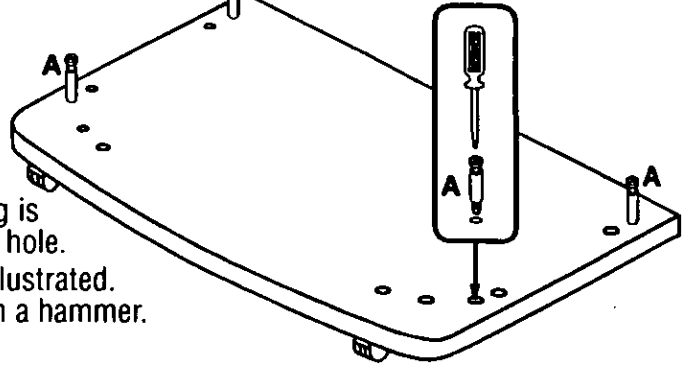

STEP 3

- Ensure arrow of cam lock housing is facing out towards the pre-drilled hole.
- Insert dowels into side panel as illustrated. If dowels are tight, tap lightly with a hammer.

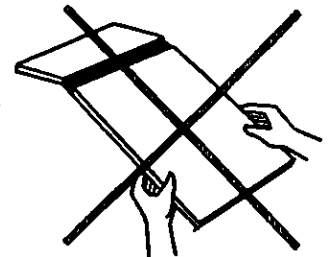
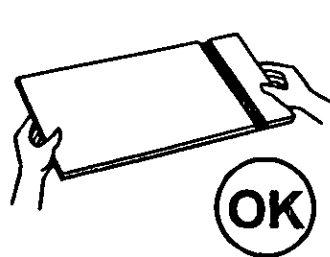
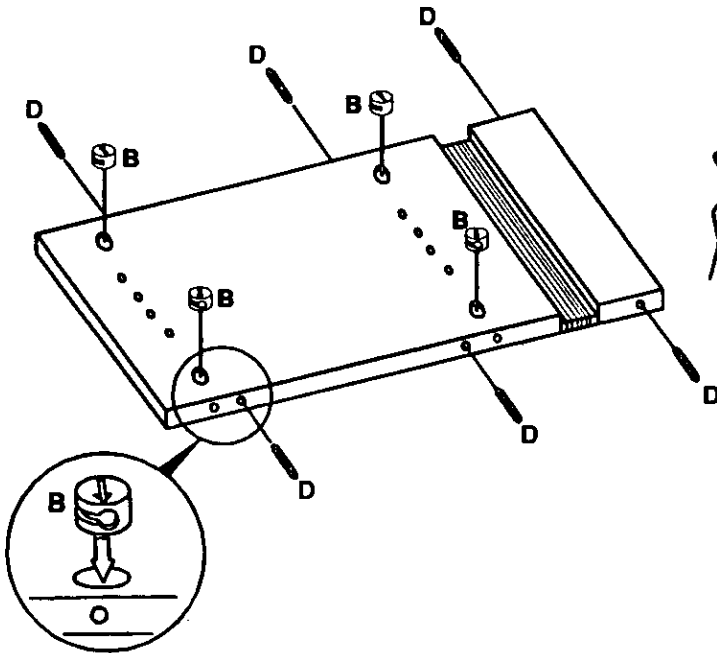

STEP 4

- After inserting side panel, turn cam lock housing clockwise to lock.

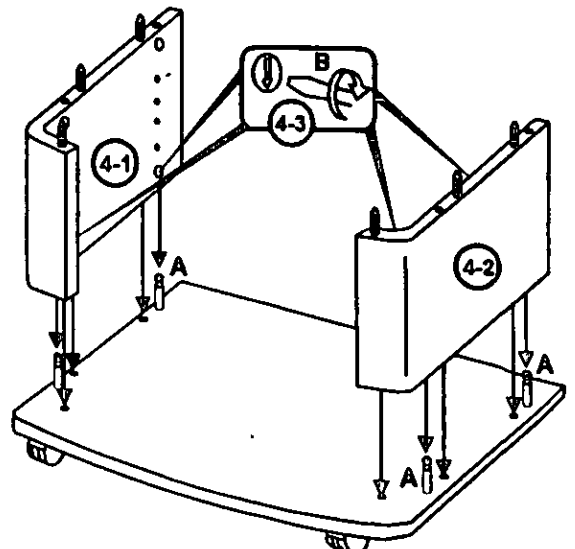

STEP 5 • Install hardware into top as illustrated.

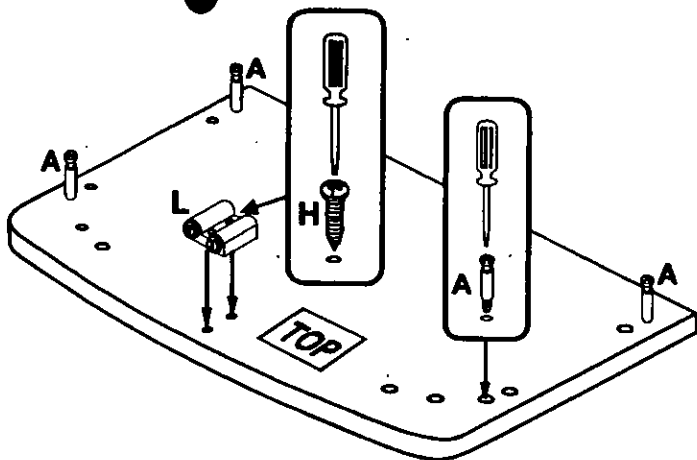

STEP 6 • After installing top, turn cam lock housing clockwise to lock.

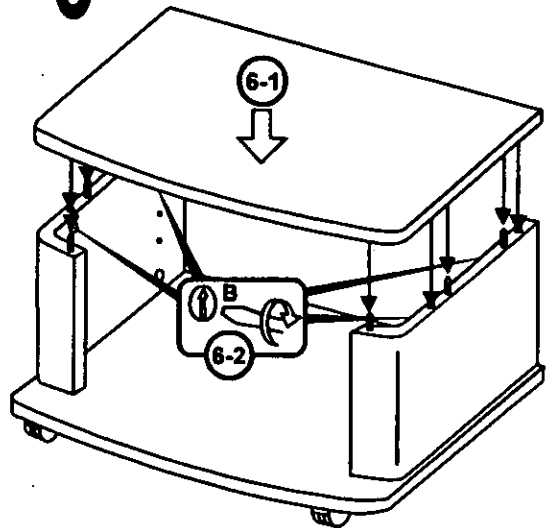

STEP 7 • Insert shelf pins. Insert shelf from rear as illustrated.

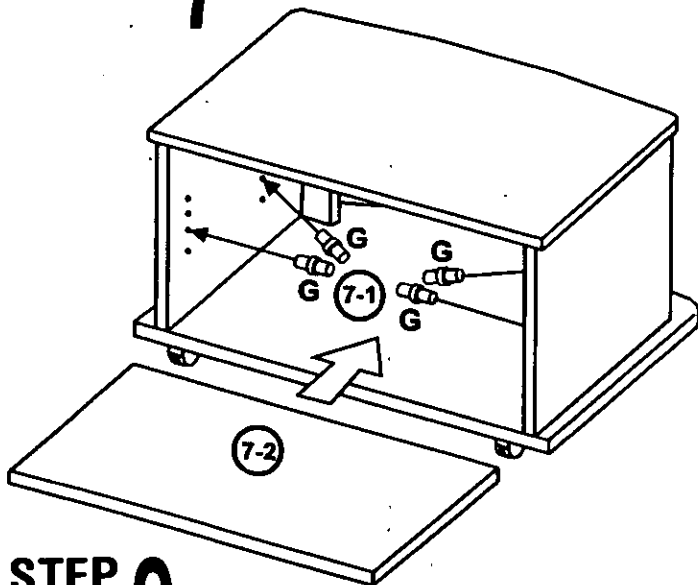

STEP 8

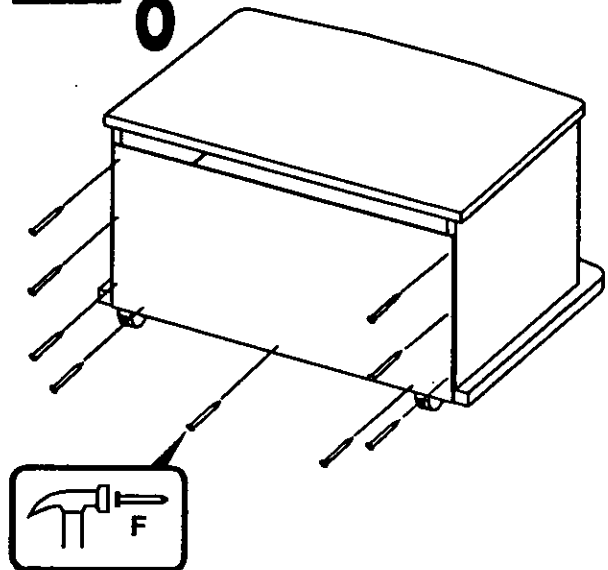

STEP 9

Glass Door Installation

(Left glass door installation shown)

- 9-1 • Insert bushings into top and bottom pre-drilled holes.
- 9-2 • Insert bottom hinge into bottom bushing.
- 9-3 • Insert top hinge into top bushing. Hold top hinge in place while sliding in glass door and tighten screws.
- 9-4 • Remove protective liner from rubber pad and fold over door as shown. Slide touch plate over rubber pad. Repeat steps 9-1 to 9-4 for right door installation.

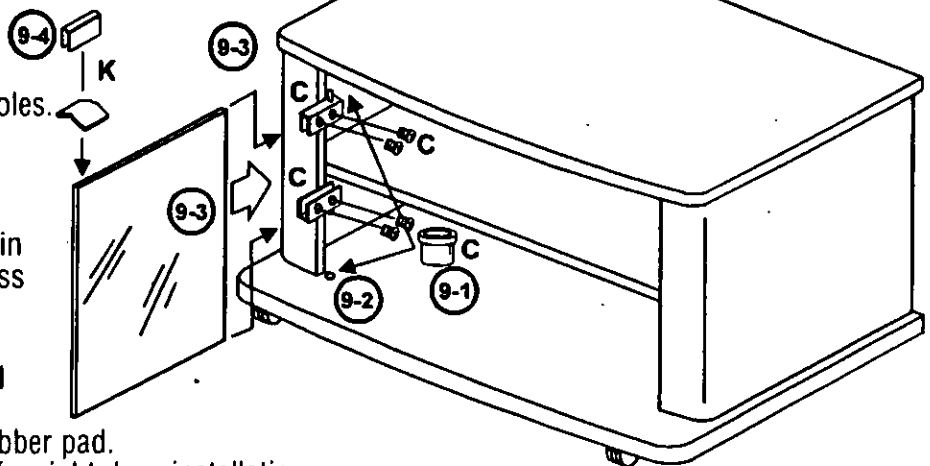

STEP 10

- Insert set location pins (see chart below for location).
- Place television on stand making sure pins are in place.

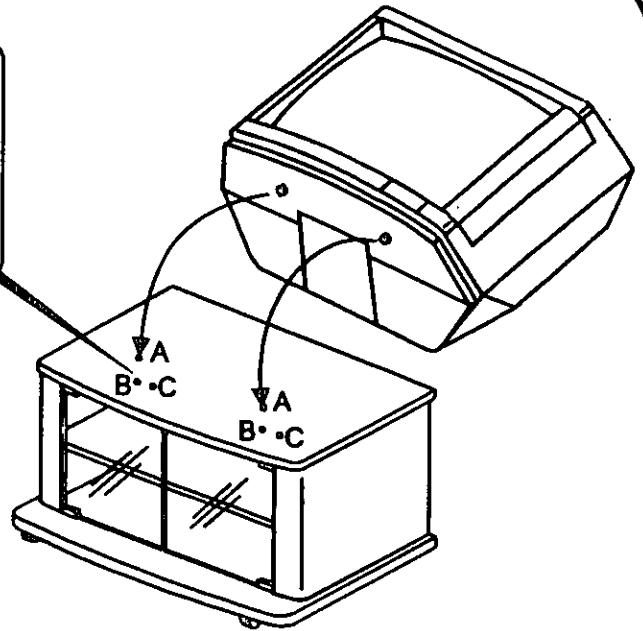
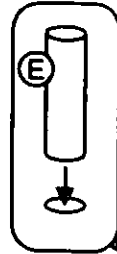

HOLE "A" - CT-27SF12T, CT-27SF14V,
CT-27SF24V, CT-27SF34V

HOLE "B" - CT-27G2V, CT-27G2UV, CT-27G12V,
CT-27G12UV, CT-27G22V, CT-27G22UV,
CT-27G32V, CT-27G32UV, CT-2758SV,
SP2719V, SP2719UV,
SP2729V, SP2729UV,

HOLE "C" - CT-2768SV, CT-27S21V

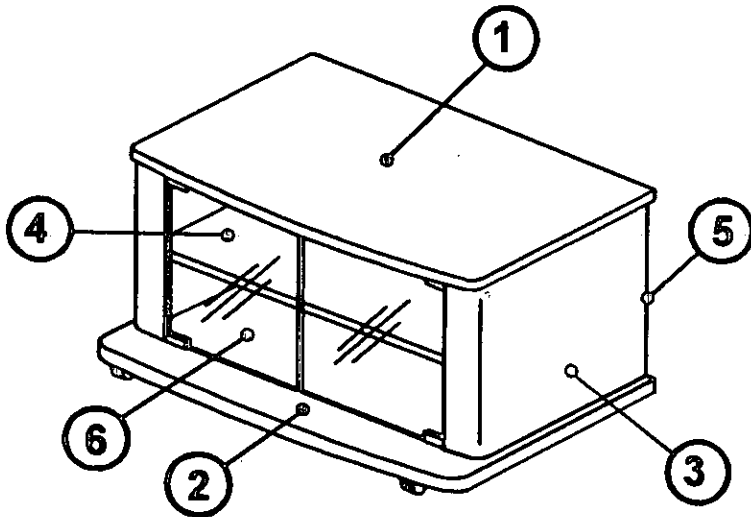

REPLACEMENT PARTS

Ref.	Description	Qty.	Part No.
1	Top	1	TKD2Q14689
2	Bottom	1	TKD2Q23372P
3	Side Panel	2	TKD2Q24776P
4	Shelf	1	TKD2Q13342-1
5	Rear Cover	1	TKD2Q17358
6	Glass Door	2	TKG2Q59460

To maintain appearance we recommend the following:

For Painted Surfaces: Use a damp cloth for cleaning. Do not use any abrasive or chemical based cleaners.

Vinyl: Vinyl does not need polishing and is remarkably resistant to almost any stain.

• **Scuff Marks:** Most scratches and scuffs can be removed with fine steel wool and furniture wax.

• **Stains:** A sponge, dipped in warm, soapy water and used to wipe lightly over vinyl will remove most stains.

NOTE: As with all indoor furniture, this unit should not be exposed to direct sunlight, extreme temperatures or moisture, as this can result in serious irreparable damage.

For improvement purposes, design and specifications are subject to change without notice.

When making a part(s) inquiry, please quote part number and description.

For parts inquiries or for out of warranty purchases:

PANASONIC SERVICES COMPANY

20421 84th Avenue South, Kent, Washington 98032 • Tel.: 1-800-833-9626 • Fax: 1-800-237-9080

© 1997 Matsushita Electric Industrial Co., Ltd. • All rights reserved. Unauthorized copying and distribution is a violation of law.